

Section View

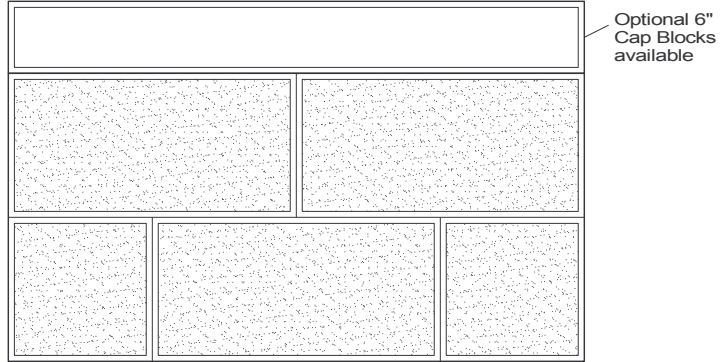

Front View

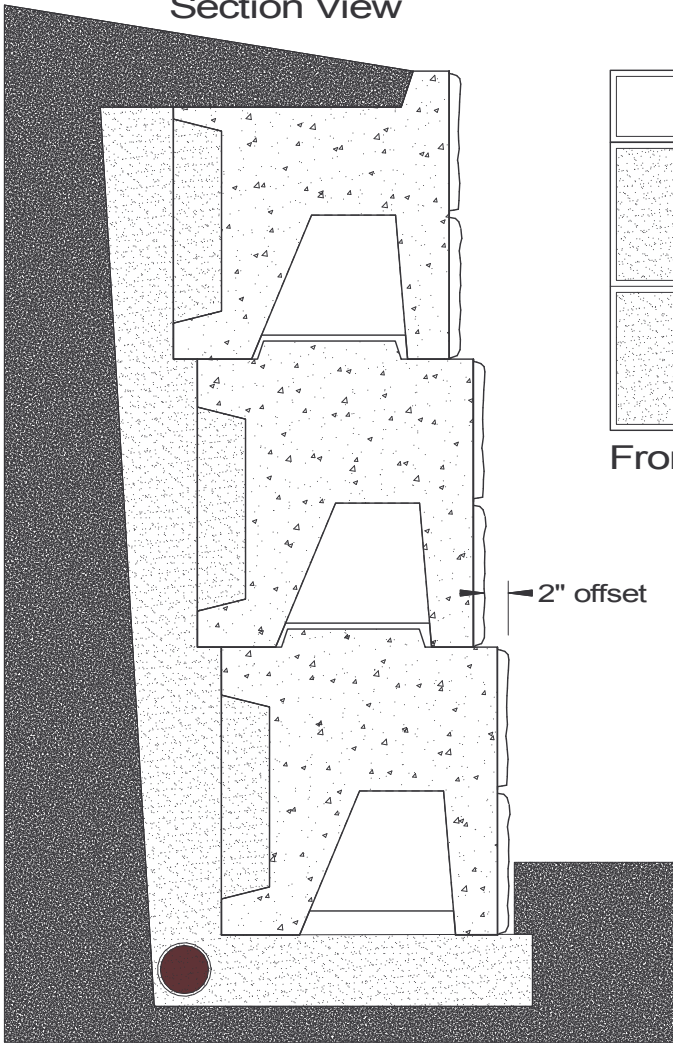
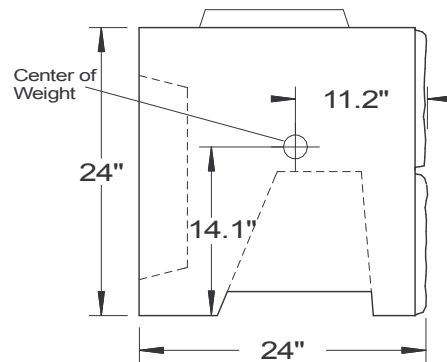

End View

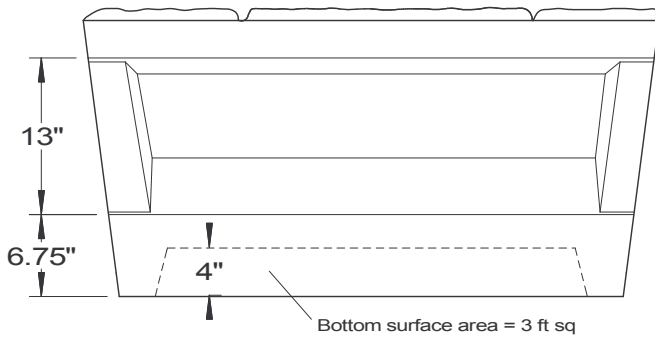

Bottom View

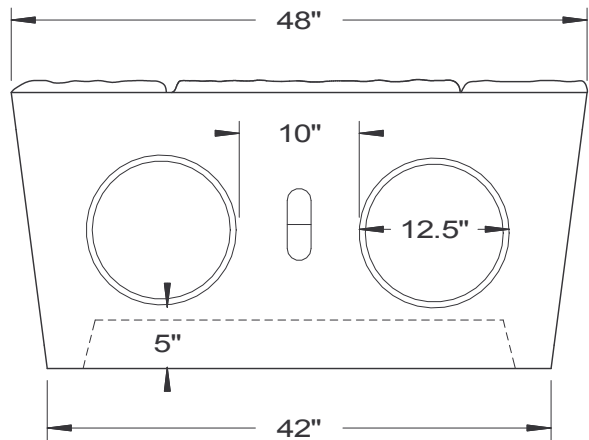

Top View

SPECIFICATIONS

Concrete Min. Strength: 4,000 psi at 28 days  
 Reinforcement: Fiber, #4 bar / ASTM A615  
 Air Entrainment: 6%  
 Weight = 1,600 lbs (2'x4' middle block)

PRECAST RETAINING WALL BLOCK

**Woodard's Concrete Products, Inc.**  
 629 Lybolt Road, Bullville, NY 10915  
 (845) 361-3471 / Fax 361-1050